

CONFIDENTIAL NOTICE: This drawing and the designs, specifications and engineering information disclosed hereon are the property of Eberhard Manufacturing Company and are not to be disseminated or reproduced without express written consent. The drawing is loaned in confidence and then only for consideration of the matter disclosed hereon. In accepting loan of this drawing, recipient agrees to keep it and the matter disclosed hereon in confidence and not to use nor permit their use in any way whatsoever by Eberhard Manufacturing Company, Division of the Eastern Company, 2184 Drake Road, Cleveland, Ohio 44116-9712. © 2014 EBERHARD MFG. CO.

REVISION HISTORY					
REV	DESCRIPTION	EN	DATE	REV BY	APVD BY
1	REVISED, REDRAWN AND CONVERTED TO 3D	5592	2-22-13	FLP	
1	ADDED: PATENTED	5683	12-12-14	FLP	MR

PART NUMBER	FINISH CODE	FINISH DESCRIPTION
9872-PKR/L	(33)	BLACK POWDER COAT RECEPTACLE W/BRUSHED STAINLESS HANDLE

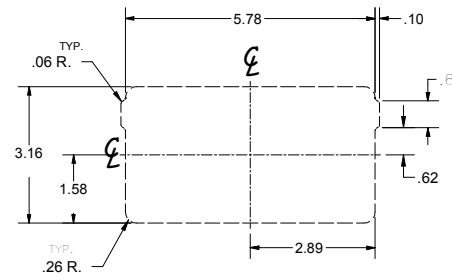
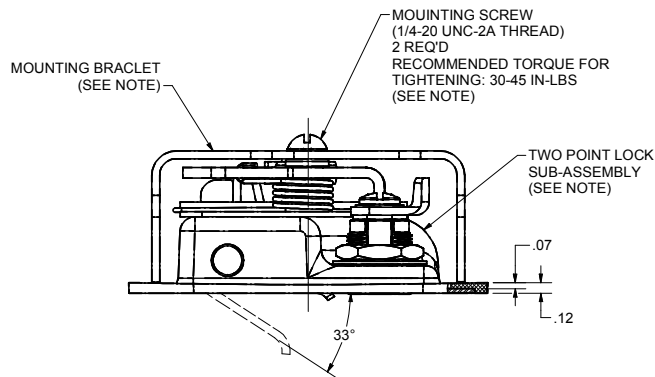
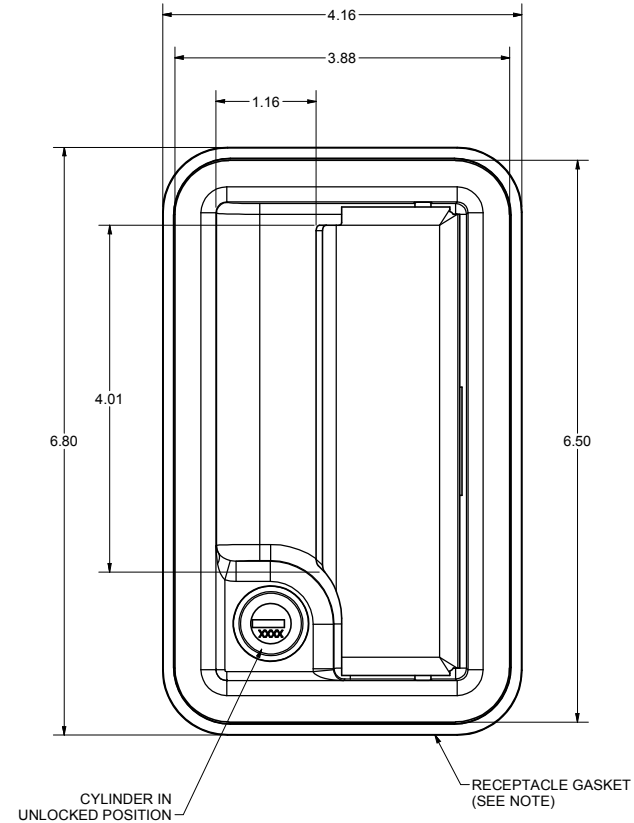
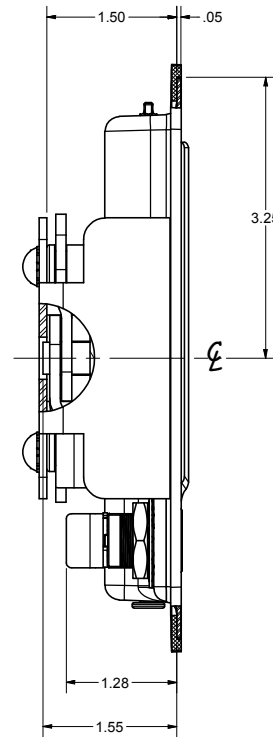
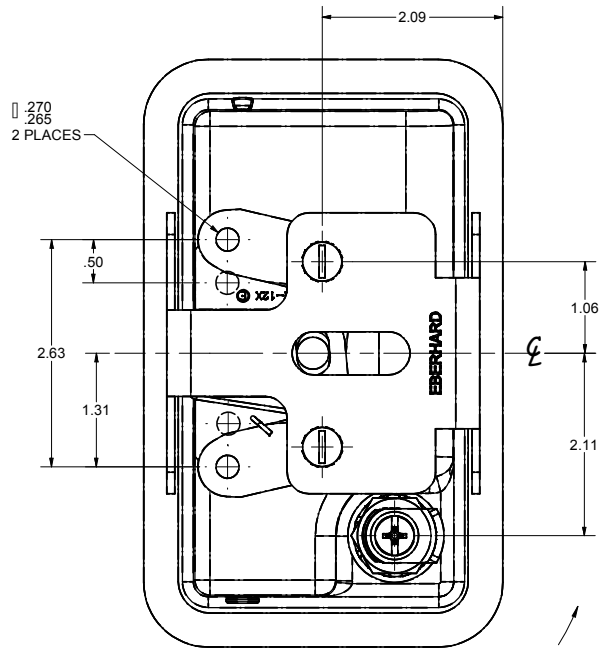

RIGHT HAND SHOWN
LEFT HAND OPPOSITE
CUSTOMER PRINT
SHEET 1 OF 2

- NOTES:
- COMPONENTS SHIPPED LOOSE IN A SECURED DOUBLE POLY BAG.
 - ASSEMBLY SUPPLIED WITH TWO DOUBLE BITTED KEYS.

SUPERSEDES DRAWING 9872-PKR/L SHEET 1 OF 2 DATED 7-5-05.

<p>THIS DOCUMENT IS IN ACCORDANCE WITH ASME Y14.15-2009</p> <p>UNLESS OTHERWISE SPECIFIED TOLERANCES ARE AS FOLLOWS:</p> <p>ANGLES: 20° 25°</p> <p>2 PLACE DEC: 0.05 0.76</p> <p>3 PLACE DEC: 0.015 0.38</p> <p>ALL HOLES: 0.005 0.13</p>		<p>DATE: 2/22/2013</p> <p>DR BY: FLP</p> <p>SCALE: FULL</p> <p>CHK BY:</p>	<p>NAME: EBERHARD MANUFACTURING CO. DIVISION OF THE EASTERN COMPANY CLEVELAND, OHIO 44146-9712</p> <p>TWO POINT LEVER LOCK SUB-ASSEMBLY</p> <p>MATERIAL: -----</p> <p>PART NUMBER: 9872-PKR/L</p>
<p>1 PATENTED</p>			