

CONFIDENTIAL NOTICE: This drawing and the designs, specifications and engineering information disclosed hereon are the property of Eberhard Manufacturing Company and are not to be disseminated or reproduced without express written consent. The drawing is loaned in confidence and then only for consideration of the matter disclosed hereon. In accepting loan of this drawing, recipient agrees to keep it and the matter disclosed hereon in confidence and not to use nor permit their use in any way subsequent to Eberhard Manufacturing Company, Division of the Eastern Company, 2184 Drake Road, Cleveland, Ohio 44116-9712. © 2012 EBERHARD MFG. CO.

REVISION HISTORY		EN	DATE
REV	DESCRIPTION		
	REVISED AND REDRAWN	5568	8/24/2012
1	REMOVE .06, REMOVE LEADER TEXT, ADD (2.96)	5900	4/26/2019

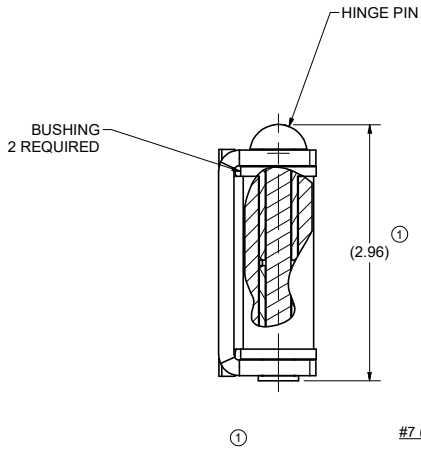

#7 (.18) MFG. STD. GA.

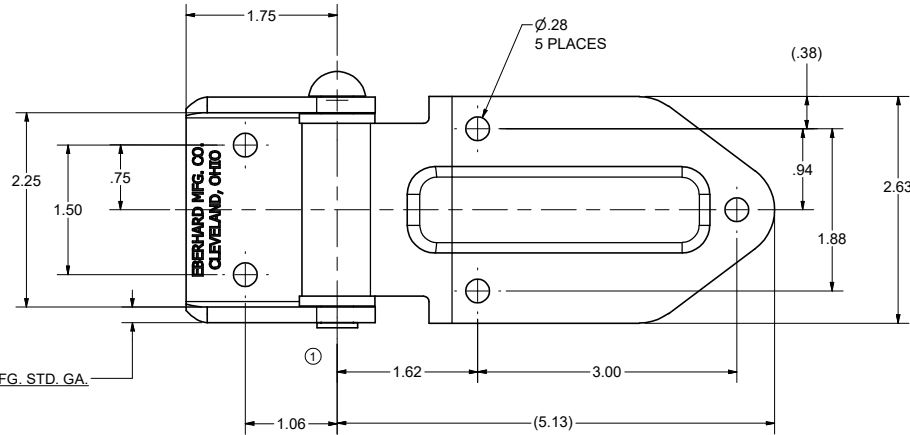

HINGE BUTT

HINGE STRAP

#9 (.15) MFG. STD. GA.

NOTES

1. FINISH (25) ZINC WITH CLEAR

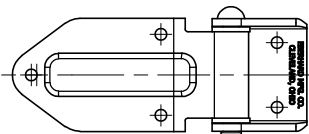

RIGHT HAND SHOWN
SCALE 1:2



SUPERSEDES DRAWING 1-5867-RL DATED 9-25-1996

CUSTOMER PRINT
SHEET 1 OF 2
LEFT HAND SHOWN
RIGHT HAND OPPOSITE

EBERHARD MANUFACTURING CO.
DIVISION OF
THE EASTERN COMPANY
CLEVELAND, OHIO 44146-9712

STEEL FLUSH HINGE ASSEMBLY

THIS DOCUMENT IS IN ACCORDANCE WITH ASME Y14.5-2009		DATE	8/22/2012
UNLESS OTHERWISE SPECIFIED TOLERANCES ARE AS FOLLOWS:		DR BY	DRG/MS
	IN	MM	
ANGLES:	± .2	± .2	SCALE
2 PLACE DEC:	± .03	± .76	
3 PLACE DEC:	± .015	± .38	CHK BY
ALL HOLES:	± .005	± .13	

MATERIAL	PART NUMBER
	5867-R/L