

CONFIDENTIAL NOTICE: This drawing and the designs, specifications and engineering information disclosed herein are the property of Eberhard Manufacturing Company and are not to be disseminated or reproduced without express written consent. The drawing is loaned in confidence and then only for consideration of the matter disclosed herein. In accepting loan of this drawing, recipient agrees to keep it and the matter disclosed herein in confidence and not to use nor permit their use in any way detrimental to Eberhard Manufacturing Company, Division of the Eastern Company, 21944 Drake Road, Cleveland, Ohio 44149-9712 © 2013 EBERHARD MFG. CO.

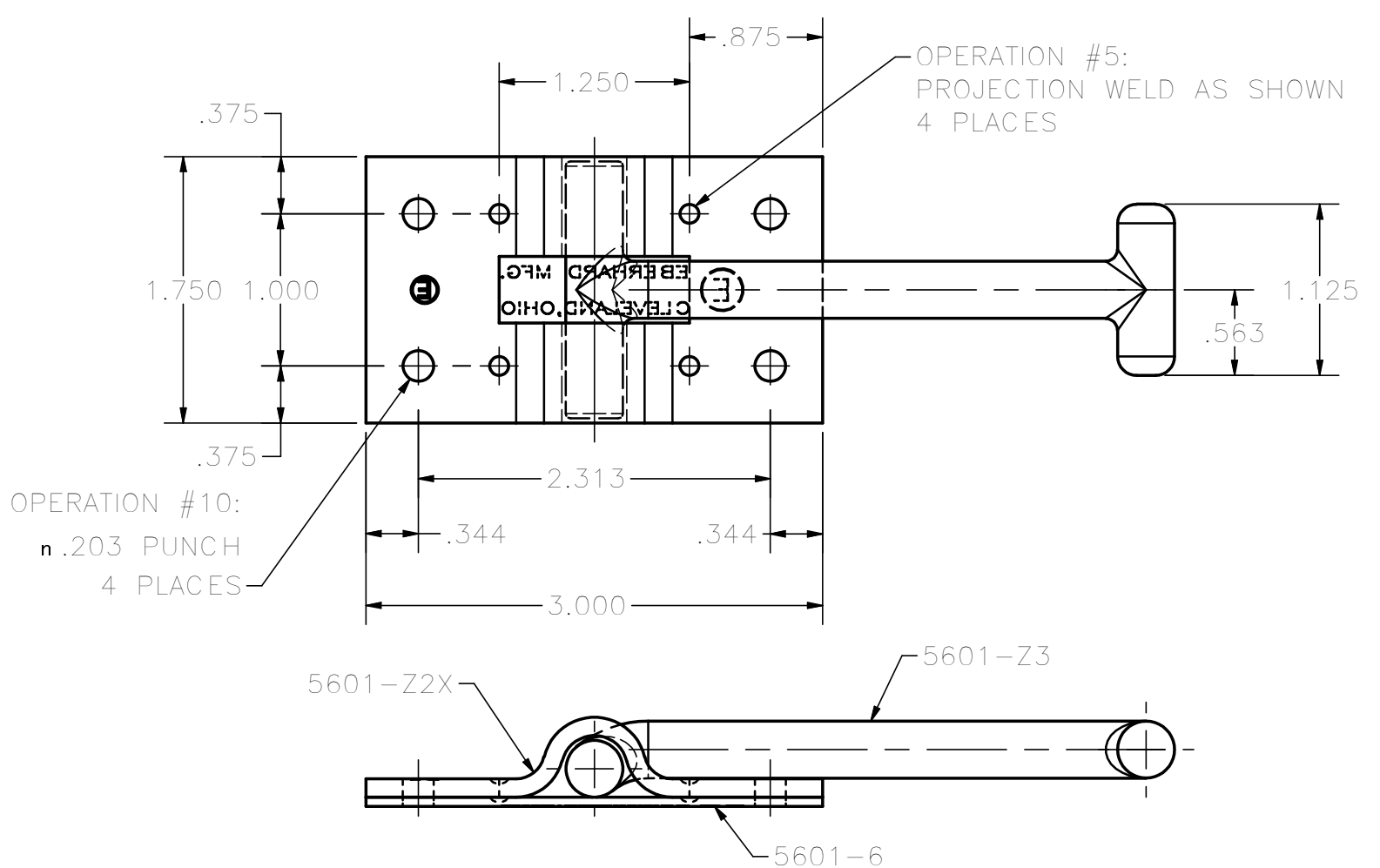

NOTE: REMOVE ALL BURRS

SUPERSEDES DRAWING 5601-Z50 DATED 6-23-99

LINEAR MEASURE: INCH UNLESS OTHERWISE SPECIFIED TOLERANCES ARE AS FOLLOWS: ANGLES: 2° 2° 2 PLACE DEC.: .03 .76 3 PLACE DEC.: .015 .38 ALL HOLES: .005 .13		DATE 6/21/2013 DR. BY FLP SCALE FULL CHK. BY	EBERHARD MANUFACTURING CO. DIVISION OF THE EASTERN COMPANY CLEVELAND, OHIO 44149-9712	NAME HOOK SUB-ASSEMBLY
CONVERTED TO 3D 5609 6-21-13		THIS DOCUMENT IS IN ACCORDANCE WITH ASME Y14.15-2009		MATERIAL -----
REV	DESCRIPTION	EN	DATE	PART NUMBER 5601-Z50

C:\Working_Folder\Archive\Pro\5\5601\5601-Z50.idw