

CONFIDENTIAL NOTICE: This drawing and the designs, specifications, and engineering information hereon are the property of Eberhard Manufacturing Company and are not to be disseminated or reproduced without express written consent. This drawing is loaned in confidence and then only for the consideration of the matter disclosed hereon. In accepting loan of this drawing, recipient agrees to keep it and the matter disclosed hereon in confidence and not to use or permit their use in any way detrimental to Eberhard Manufacturing Company, Division of The Eastern Company, 21944 Drake Road, Cleveland, Ohio, 44149-9712 © 2021 EBERHARD MFG. CO.

REVISION HISTORY					
REV	DESCRIPTION	EN	DATE	REV. BY	APVD BY
-	RELEASED WAS M13346	6023	10/8/2021	VRB	MR

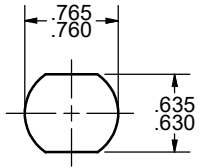

RECOMMENDED CUTOUT

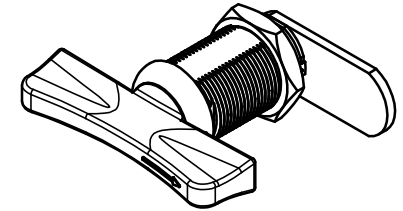
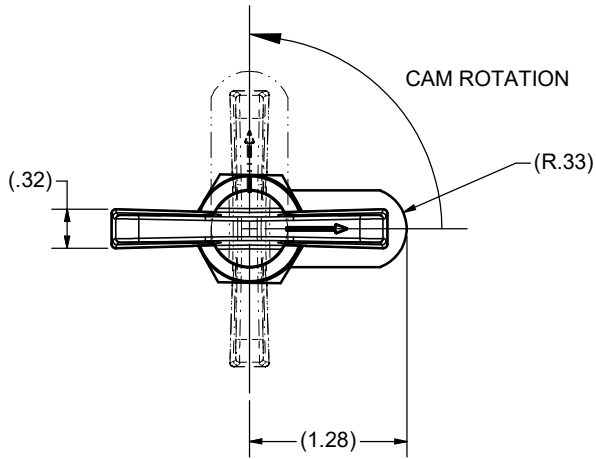
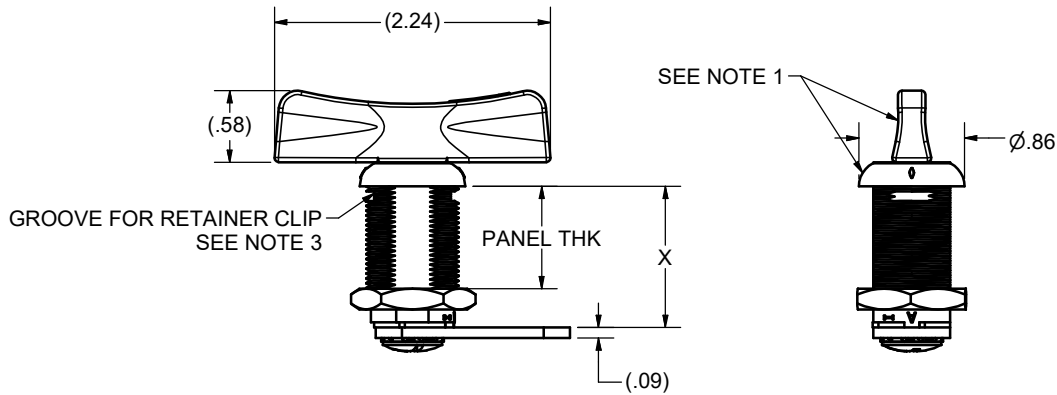

TABLE		
PART NUMBER	X DIM	MAX PANEL THK
15-524	.65 [16.5mm]	.33 [8.5mm]
21-524	.90 [22.8mm]	.58 [14.8mm]
28-524	1.15 [29.1mm]	.83 [21.1mm]
34-524	1.39 [35.4mm]	1.08 [27.4mm]
40-524	1.63 [41.5mm]	1.32 [33.5mm]



- NOTES:
- 1) EBERHARD FINISH: (.42) TEXTURED BLACK POWDER ON BARREL FACE AND KNOB.
 - 2) SUPPLIED WITH NUT, SHIPPED LOOSE IN SEALED POLY BAG.
 - 3) OPTIONAL RETAINER CLIP AVAILABLE.

THIS DOCUMENT IS IN ACCORDANCE WITH ASME Y14.5-2009		
LINEAR MEASUREMENT- INCH	DATE	
UNLESS OTHERWISE SPECIFIED TOLERANCES ARE AS FOLLOWS:	10/8/2021	
ANGLES:	± 2°	± 2°
2 PLACE DEC.:	± .03	± .76
3 PLACE DEC.:	± .015	± .38
ALL HOLES:	± .005	± .13

EBERHARD MANUFACTURING CO.
DIVISION OF
THE EASTERN COMPANY
CLEVELAND, OHIO 44149-9712

NAME		TEE HANDLE HEADED QUARTER TURN LATCH	
DATE		10/8/2021	
DWN. BY		ibemot	
SCALE		1:1	
CHK. BY			
MATERIAL	PART NUMBER		
	524 CHART		