

CONFIDENTIAL NOTICE: This drawing and the designs, specifications and engineering information disclosed hereon are the property of Eberhard Manufacturing Company and are not to be disseminated or reproduced without express written consent. The drawing is loaned in confidence and then only for consideration of the matter disclosed hereon. In accepting loan of this drawing, recipient agrees to keep it and the matter disclosed hereon in confidence and not to use nor permit their use in any way detrimental to Eberhard Manufacturing Company, Division of the Eastern Company. 21944 Drake Road, Cleveland, Ohio 44149-9712 © 2016 EBERHARD MFG. CO.

REVISION HISTORY				
REV	DESCRIPTION	EN	DATE	APVD. BY
	REVISED AND REDRAWN, CONVERTED TO 3D	EN 5754	5/27/2016	SAA LSW

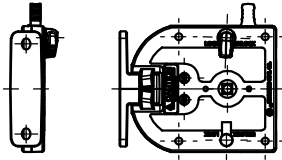

206-UL-23  
SLAM LOCK W/VERTICAL  
LOCKING BUTTON, INSIDE  
LOCKING KNOB & STRIKER  
SCALE: QUARTER

PART NO.	DESCRIPTION
206-UR/L-23	ASSEMBLY WITH STRIKER P/N: 206-15-01
206-R/L-23	ASSEMBLY WITHOUT STRIKER P/N: 206-15-01

**CAUTION**  
THIS PRODUCT WILL REMAIN UNLOCKED  
WHEN DOOR IS CLOSED

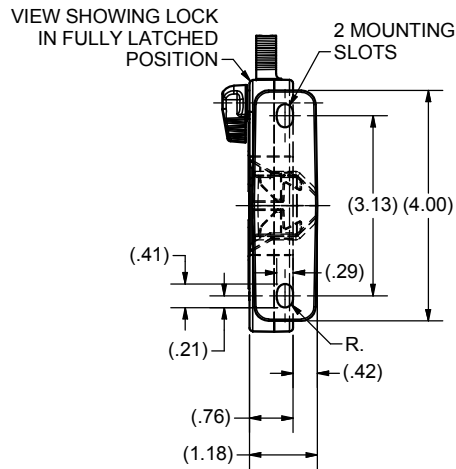
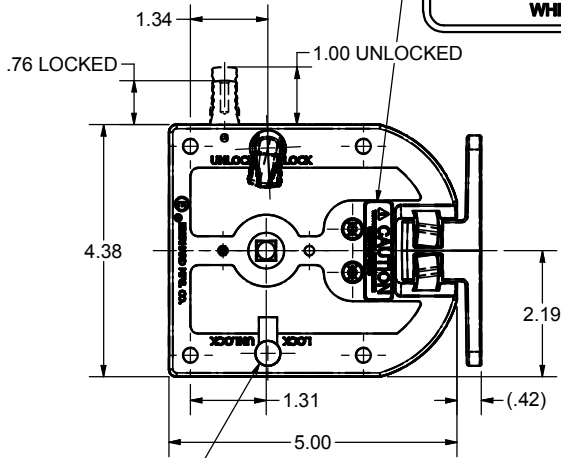

SERIAL NUMBER STICKER  
NOTE TO CUSTOMER:  
REMOVAL OF STICKER  
VOIDS WARRANTY

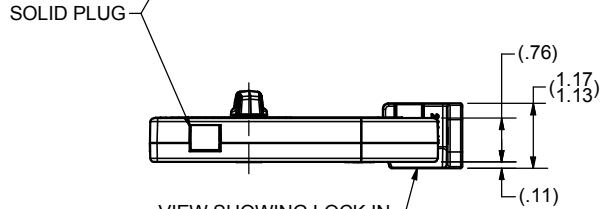
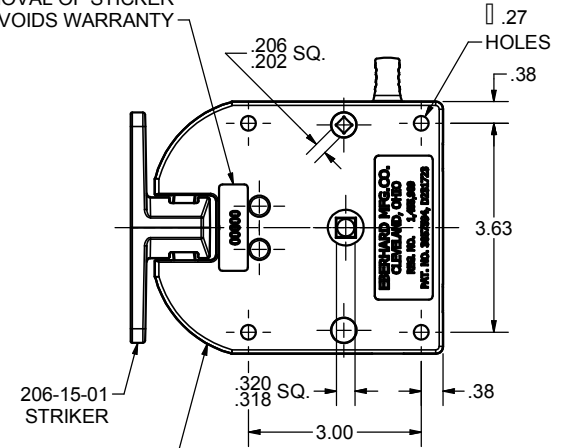

**APPROVED**  
THIS LOCK ASSEMBLY MEETS ALL FMVSS 206  
SAFETY STANDARDS WHEN USED AND TESTED  
WITH AN EBERHARD CERTIFIED STRIKER

206-R-23  
SLAM LOCK W/VERTICAL  
LOCKING BUTTON &  
INSIDE LOCKING KNOB

CUSTOMER PRINT  
RIGHT HAND SHOWN  
LEFT HAND OPPOSITE

**EBERHARD MANUFACTURING CO.**  
DIVISION OF  
THE EASTERN COMPANY  
CLEVELAND, OHIO 44149-9712

- NOTES:  
1) THIS SLAM LOCK AND STRIKER ASSEMBLY MEET ALL REQUIREMENTS FOR FMVSS 206 SAFETY STANDARD WHEN MOUNTED WITH (6) 1/4-20 GRADE 8 BOLTS. RECOMMENDED TORQUE FOR TIGHTENING: 10-14 ft.-lbs.  
2) FINISH: COMBINATION OF: (23) E-COAT AND (69) FLUOROCARBON COATING COMPONENTS

THIS DOCUMENT IS IN ACCORDANCE WITH ASME Y14.5-2009

LINEAR MEASURE: INCH		DATE
UNLESS OTHERWISE SPECIFIED		5/24/2016
TOLERANCES ARE AS FOLLOWS:		DR BY
		SAA
ANGLES:	∠ .2∠ ∠ .2∠	SCALE
2 PLACE DEC.:	∠ .03 ∠ .76	HALF
3 PLACE DEC.:	∠ .015 ∠ .38	CHK BY
ALL HOLES:	∠ .005 ∠ .13	

NAME SLAM LOCK W/VERTICAL LOCKING BUTTON, INSIDE LOCKING KNOB & STRIKER	
MATERIAL	CHART
206-UR/L-23	206-UR/L-23

SUPERSEDES DRAWING 206-UR/L-23 DATED 7-15-2011.

C:\Working\_Folder\Archive\Pro2\206\_7\206\206-URL-23.idw