

CONFIDENTIAL NOTICE: This drawing and the designs, specifications and engineering information disclosed hereon are the property of Eberhard Manufacturing Company and are not to be disseminated or reproduced without express written consent. The drawing is loaned in confidence and then only for consideration of the matter disclosed hereon. In accepting loan of this drawing, recipient agrees to keep it and the matter disclosed hereon in confidence and not to use nor permit their use in any way whatsoever by Eberhard Manufacturing Company, Division of the Eastern Company, 2184 Drake Road, Cleveland, Ohio 44149-9712, © 2014 EBERHARD MFG. CO.

REVISION HISTORY				
REV	DESCRIPTION	DN	DATE	REV BY / APVD BY
	REVISED AND REDRAWN, CONVERTED TO 3D	5626	5-27-2011	FLP / MR
1	ADDED 8400-55, 203 WAS 20	5630	11-14-14	FLP / MR
2	MODIFIED SUGGESTED CUTOUT VIEW	5722	09/25/2015	CLB / MR

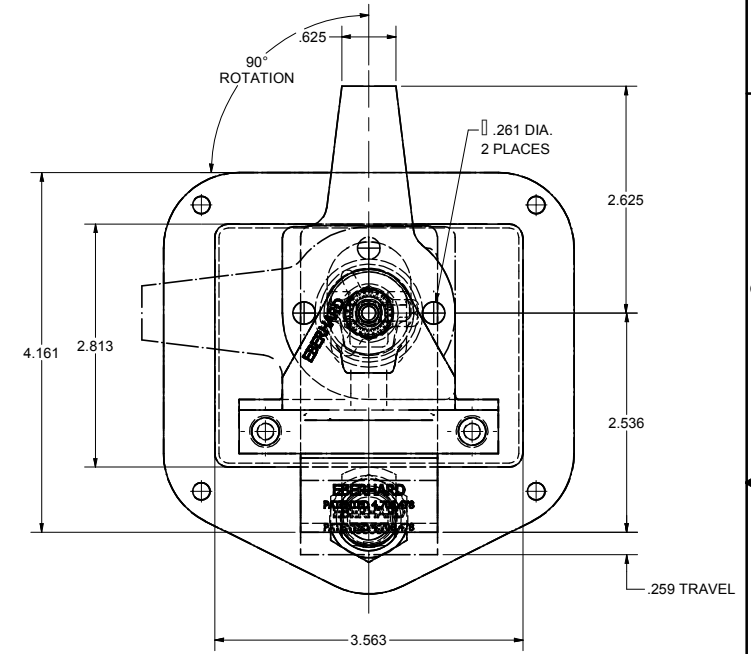
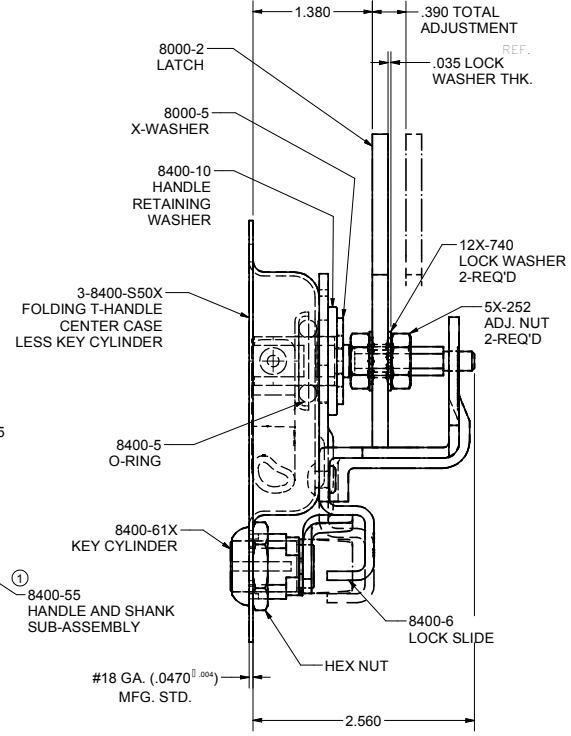
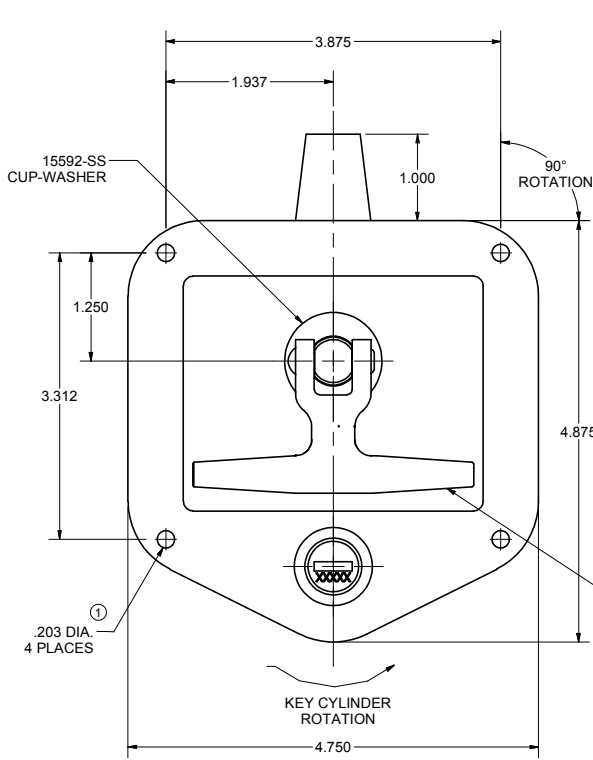

NOTE:
GREASE BOTTOM OF LOCK SLIDE PRIOR
TO ASSEMBLY USING LUBRIPLATE 1200-2.

NOTE:
OPTIONAL GASKET AVAILABLE
ORDER P/N: 16553
MATERIAL: EPDM CLOSED CELL SPONGE
THICKNESS: .19
COLOR: BLACK

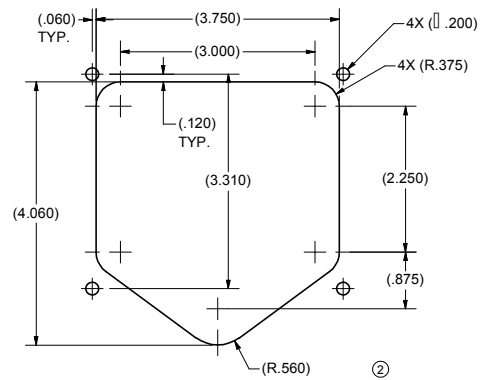

SUGGESTED OUTLINE OF CUTOUT
SCALE .750

RIGHT HAND SHOWN
LEFT HAND OPPOSITE

EBERHARD MANUFACTURING CO.
DIVISION OF
THE EASTERN COMPANY
CLEVELAND, OHIO 44149-9712

UNLESS OTHERWISE SPECIFIED TOLERANCES ARE AS FOLLOWS:		DATE 5-27-2011	NAME KEY LOCKING SINGLE POINT RECESSED FOLDING T-HANDLE W/ADJUSTABLE LATCH AND WATER RESISTANT FEATURE
ANGLES:	∠ .25	DR BY M/M	MATERIAL
2 PLACE DEC.:	∠ .03	SCALE FULL	PART NUMBER 2-8400-SSR/L
3 PLACE DEC.:	∠ .015	CHK BY	
ALL HOLES:	∠ .005		

SUPERSEDES DRAWING 2-8400-SSR/L DATED 3-10-03.

C:\Working_Folder\Archive\Proj\818400\2-8400-SS RL.dwg