

CONFIDENTIAL NOTICE: This drawing and the designs, specifications and engineering information disclosed hereon are the property of Eberhard Manufacturing Company and are not to be disseminated or reproduced without express written consent. The drawing is loaned in confidence and then only for consideration of the matter disclosed hereon. In accepting loan of this drawing, recipient agrees to keep it and the matter disclosed hereon in confidence and not to use nor permit their use in any way detrimental to Eberhard Manufacturing Company, Division of the Eastern Company, 21944 Drake Road, Cleveland, Ohio 44149-9712 © 2018 EBERHARD MFG. CO.

REVISION HISTORY					
REV	DESCRIPTION	EN	DATE	REV. BY	APVD. BY
	RELEASE TO PRODUCTION/REF-PP11430-D	5870	9/14/2018	KAB	MR

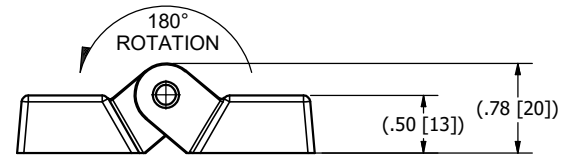
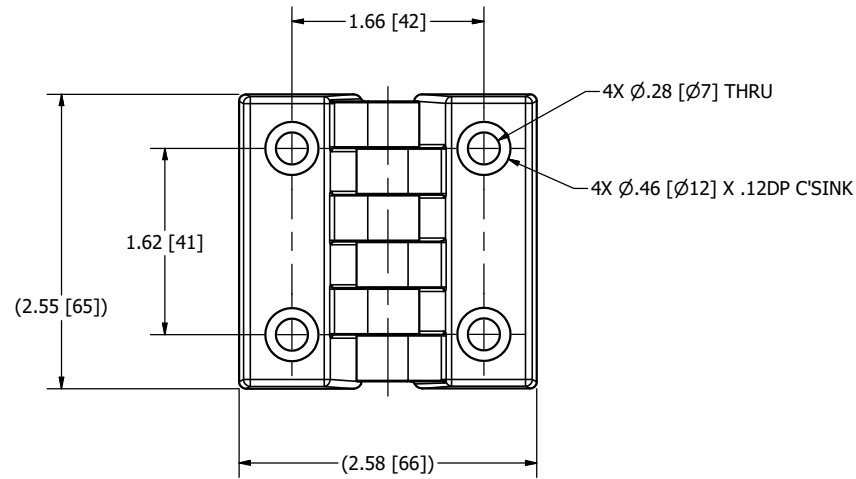
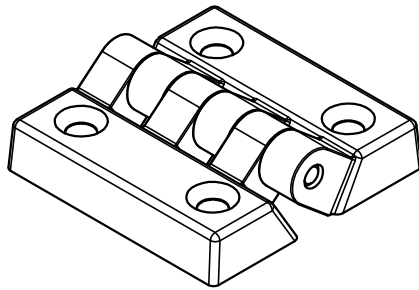

- NOTES:
- 1) MATERIAL : POLYAMIDE BLACK,
 - 2) EBERHARD FINISH: (MB) MATTE BLACK, W/ (25) ZINC PLATED PIN.
 - 3) WORKING TEMP: -55 TO 190 DEGREES (CELSIUS)
 - 4) THREE KNUCKLE CONSTRUCTION.

THIS DOCUMENT IS IN ACCORDANCE WITH ASME Y14.5-2009

LINEAR MEASURE: INCH[mm]		DATE
UNLESS OTHERWISE SPECIFIED		9/14/2018
TOLERANCES ARE AS FOLLOWS:		DR BY
	IN	MM
ANGLES:	± 2'	± 2'
2 PLACE DEC.:	± .03	± .76
3 PLACE DEC.:	± .015	± .38
ALL HOLES:	± .005	± .13

CUSTOMER PRINT
SHEET 1 OF 2

EBERHARD MANUFACTURING CO.
DIVISION OF
THE EASTERN COMPANY
CLEVELAND, OHIO 44149-9712

NAME	
HINGE, 3-STRAP, POLYAMIDE	
MATERIAL	PART NUMBER
	17076