

CONFIDENTIAL NOTICE: This drawing and the designs, specifications and engineering information disclosed hereon are the property of Eberhard Manufacturing Company and are not to be disseminated or reproduced without express written consent. The drawing is loaned in confidence and then only for consideration of the matter disclosed hereon. In accepting loan of this drawing, recipient agrees to keep it and the matter disclosed hereon in confidence and not to use nor permit their use in any way detrimental to Eberhard Manufacturing Company, Division of the Eastern Company. 21944 Drake Road, Cleveland, Ohio 44149-9712 © 2009 EBERHARD MFG. CO.

NOTE:

1. ALL VISIBLE EXTERIOR SURFACES TEXTURED PER MOLDTECH MT-1055-5.
2. CUSTOMER TO PERFORM IMPACT TESTING.

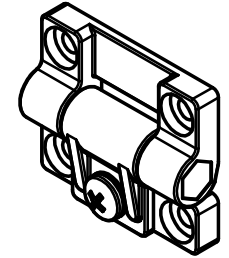
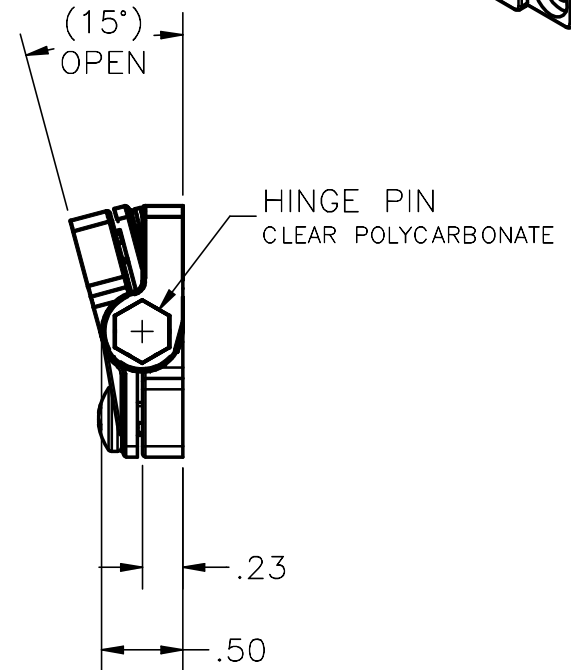
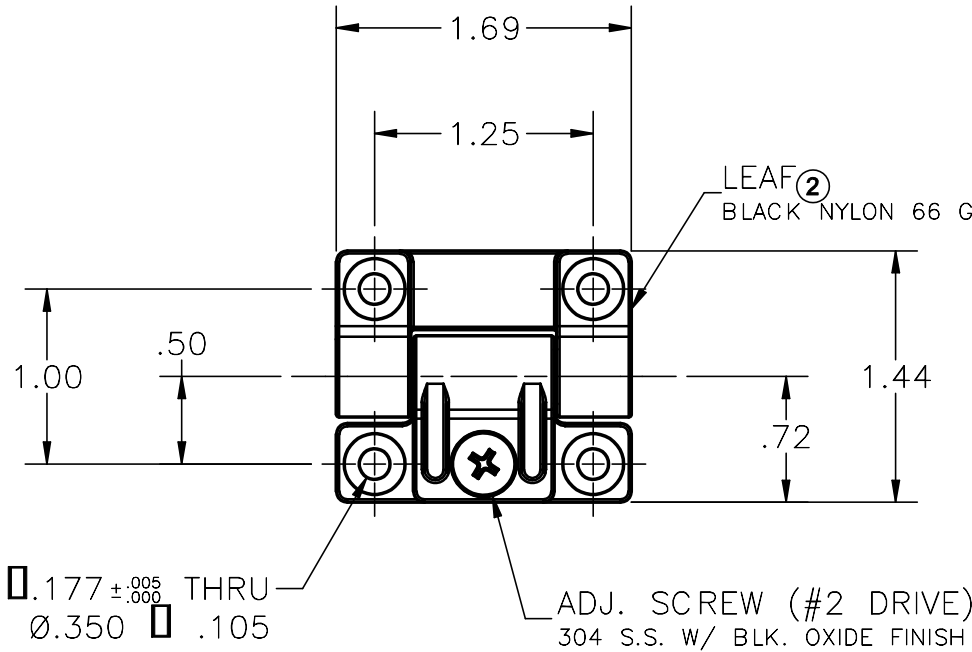

CUSTOMER PRINT SHEET 1 OF 2

FINISH: (MB) MATTE BLACK.

REV	DESCRIPTION	EN	DATE
1	RELEASED, WAS M9411	5402	5-15-09
2	CHANGED MATERIAL WAS BLACK DUPONT DELRIN 100ST BK602	EN 5428	11-13-09

REVISION HISTORY

UNLESS OTHERWISE SPECIFIED TOLERANCES ARE AS FOLLOWS:	
ANGLES:	$\square 2$
2 PLACE DEC.:	$\square .03$
3 PLACE DEC.:	$\square .015$
ALL HOLES:	$\square .005$

DATE	5/5/2009
DR. BY	SAT
SCALE	FULL
CHK. BY	

EBERHARD MANUFACTURING CO.
DIVISION OF
THE EASTERN COMPANY
CLEVELAND, OHIO 44149-9712

NAME		FRICTION HINGE	
MATERIAL	NOTED	PART NUMBER	16945