

**CONFIDENTIAL NOTICE:** This drawing and the designs, specifications and engineering information disclosed herein are the property of Eberhard Manufacturing Company and are not to be disseminated or reproduced without express written consent. The drawing is loaned in confidence and then only for consideration of the matter disclosed herein. In accepting loan of this drawing, recipient agrees to keep it and the matter disclosed herein in confidence and not to use nor permit their use in any way detrimental to Eberhard Manufacturing Company, Division of the Eastern Company, 21944 Drake Road, Cleveland, Ohio 44149-9712 © 2016 EBERHARD MFG. CO.

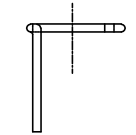

FULL SIZE

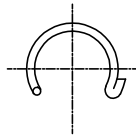
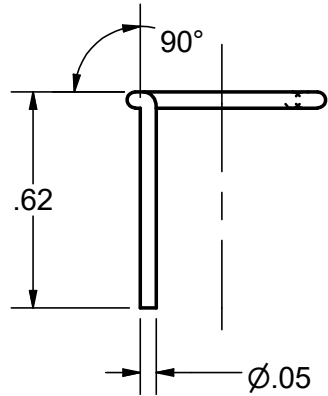
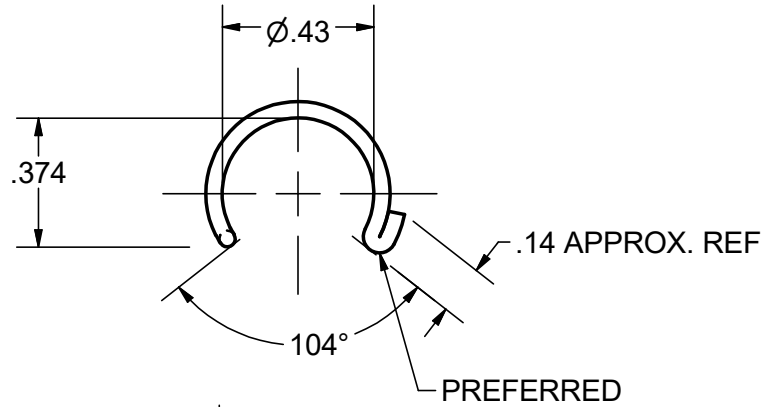

- NOTES:  
 1. STAINLESS STEEL WIRE, 300 SERIES  
 2. FINISH: PLAIN, FC (01)  
 3. USE WITH BALL STUD PART NUMBER 16301-25

CUSTOMER PRINT  
SHEET 1 OF 2

<table border="1"> <tr> <td colspan="2">LINEAR MEASURE: INCH</td> <td>DATE</td> <td colspan="3">EBERHARD MANUFACTURING CO.</td> <td>NAME</td> </tr> <tr> <td colspan="2">UNLESS OTHERWISE SPECIFIED TOLERANCES ARE AS FOLLOWS:</td> <td>3/11/2016</td> <td colspan="3">DIVISION OF</td> <td rowspan="2">SAFETY RETAINING CLIP 30 MM SIZE, FOR 13 MM BALL STUD</td> </tr> <tr> <td colspan="2"></td> <td>DR. BY</td> <td colspan="3">THE EASTERN COMPANY</td> </tr> <tr> <td colspan="2"></td> <td>GJB</td> <td colspan="3">CLEVELAND, OHIO 44149-9712</td> <td>MATERIAL</td> </tr> <tr> <td colspan="2"></td> <td>SCALE</td> <td colspan="3">THIS DOCUMENT IS IN ACCORDANCE WITH ASME</td> <td>PART NUMBER</td> </tr> <tr> <td colspan="2"></td> <td>2X</td> <td colspan="3">Y14.15-2009</td> <td>SEE ABOVE</td> </tr> <tr> <td colspan="2"></td> <td>CHK. BY</td> <td colspan="3"></td> <td>16302-SS</td> </tr> <tr> <td colspan="2"></td> <td>MR</td> <td colspan="3"></td> <td></td> </tr> </table>						LINEAR MEASURE: INCH		DATE	EBERHARD MANUFACTURING CO.			NAME	UNLESS OTHERWISE SPECIFIED TOLERANCES ARE AS FOLLOWS:		3/11/2016	DIVISION OF			SAFETY RETAINING CLIP 30 MM SIZE, FOR 13 MM BALL STUD			DR. BY	THE EASTERN COMPANY					GJB	CLEVELAND, OHIO 44149-9712			MATERIAL			SCALE	THIS DOCUMENT IS IN ACCORDANCE WITH ASME			PART NUMBER			2X	Y14.15-2009			SEE ABOVE			CHK. BY				16302-SS			MR					<table border="1"> <tr> <td>2</td> <td>REVISED NOTE</td> <td>5840</td> <td>2-16-18</td> <td>FLP</td> <td>MR</td> </tr> <tr> <td>1</td> <td>REVISED TITLE</td> <td>5821</td> <td>9-22-17</td> <td>FLP</td> <td>MR</td> </tr> <tr> <td></td> <td>RELEASED</td> <td>5743</td> <td>03/11/2016</td> <td>GJB</td> <td>MR</td> </tr> <tr> <td>REV</td> <td>DESCRIPTION</td> <td>EN</td> <td>DATE</td> <td>REV BY</td> <td>APVD BY</td> </tr> </table>		2	REVISED NOTE	5840	2-16-18	FLP	MR	1	REVISED TITLE	5821	9-22-17	FLP	MR		RELEASED	5743	03/11/2016	GJB	MR	REV	DESCRIPTION	EN	DATE	REV BY	APVD BY
LINEAR MEASURE: INCH		DATE	EBERHARD MANUFACTURING CO.			NAME																																																																																
UNLESS OTHERWISE SPECIFIED TOLERANCES ARE AS FOLLOWS:		3/11/2016	DIVISION OF			SAFETY RETAINING CLIP 30 MM SIZE, FOR 13 MM BALL STUD																																																																																
		DR. BY	THE EASTERN COMPANY																																																																																			
		GJB	CLEVELAND, OHIO 44149-9712			MATERIAL																																																																																
		SCALE	THIS DOCUMENT IS IN ACCORDANCE WITH ASME			PART NUMBER																																																																																
		2X	Y14.15-2009			SEE ABOVE																																																																																
		CHK. BY				16302-SS																																																																																
		MR																																																																																				
2	REVISED NOTE	5840	2-16-18	FLP	MR																																																																																	
1	REVISED TITLE	5821	9-22-17	FLP	MR																																																																																	
	RELEASED	5743	03/11/2016	GJB	MR																																																																																	
REV	DESCRIPTION	EN	DATE	REV BY	APVD BY																																																																																	

C:\TEMP\260bcc9-86e0-427b-a858-c2866604055c\FASTENER\CLIPS\WIRE FORM\16302-SS SH1.idw