

CONFIDENTIAL NOTICE: This drawing and the design, specifications and engineering information disclosed herein are the property of Eberhard Manufacturing Company and are not to be distributed or reproduced without express written consent. The drawing is issued in confidence and may be controlled by the name of the design. In copying this drawing, you agree to keep the name of the design in confidence and not to use the part for any other use.

REVISION HISTORY				
REV	DESCRIPTION	EN	DATE	REV BY / AP'D BY
1	RELEASED TO PRODUCTION (WAS 2348978-LIK SHEET 1 OF 2)	EN 8644	07/2014	GAB / MS
1	ADDED DOW CORNING GREASE NOTE	EN 5679	09/16/2014	MAM / LSW
2	REVISED DIMENSIONS	EN 5679	11/7/2014	SAA / LSW
3	UPDATE GRAPHICS, UPDATE PATENT STATUS	5900	4/26/2019	VPS / MS

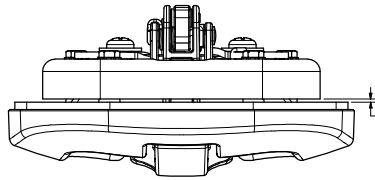

VIEW OF HANDLE WITH BRACKETS

1/16" MOUNTING PANEL THICKNESS

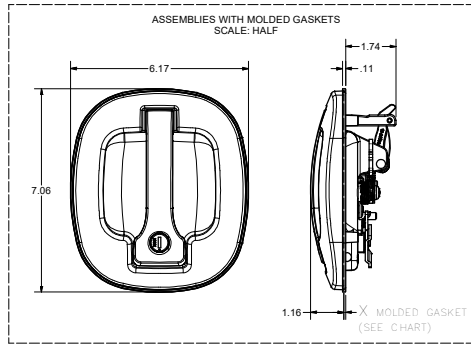

ASSEMBLIES WITH MOLDED GASKETS SCALE: HALF

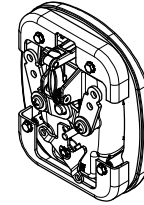

21100 SERIES MOUNTING BRACKETS (REF: 21100-MHPK) SCALE: HALF

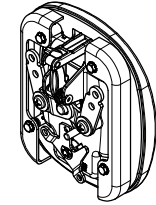

21100LB SERIES LONG MOUNTING BRACKETS (REF: 21100LB-MHPK) SCALE: HALF

NOTE: MOUNTING BRACKETS AND (4) MOUNTING SCREWS SHIPPED LOOSE IN A SECURED POLY BAG.

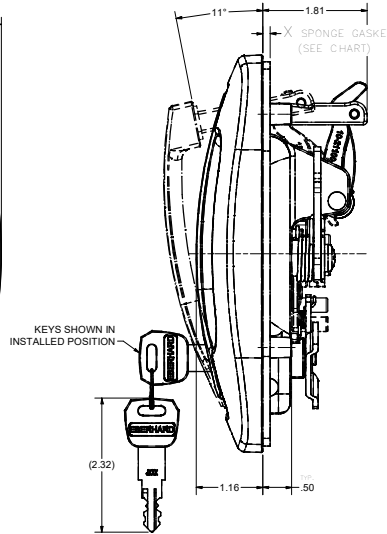
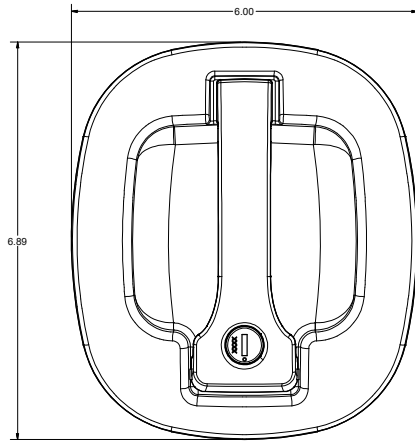

KEYS SHOWN IN INSTALLED POSITION

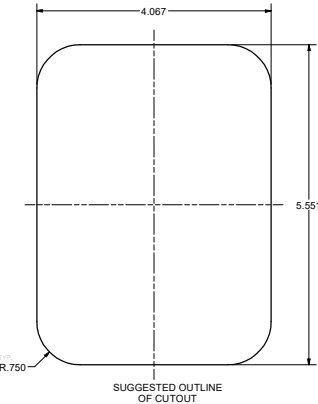
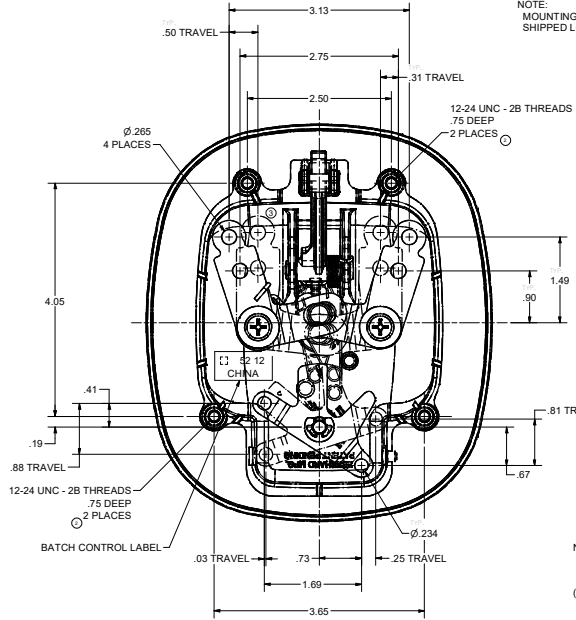

SUGGESTED OUTLINE OF CUTOUT

- NOTES:
- FINISH AVAILABLE:
 - A) CHROME RECEPTACLE & HANDLE, FC (03)
 - B) BLACK POWDER (POLY SEMI-GLOSS) RECEPTACLE & HANDLE, FC (30)
 - C) BLACK POWDER (POLY SEMI-GLOSS) RECEPTACLE & CHROME HANDLE, FC (31)
 - D) BLACK POWDER (TEXTURED) RECEPTACLE & HANDLE, FC (42)
 - E) BLACK POWDER (TEXTURED) RECEPTACLE & CHROME HANDLE, FC (35)
 - LUBRIPLATE AERO OR EQUIVALENT GREASE USED ON ALL MOVING COMPONENTS AT CONTACT POINTS.
 - DOW CORNING #44 GREASE USED ON CYLINDER WAFERS
 - MOUNTING BRACKETS AND MOUNTING SCREWS ARE FURNISHED WITH ZINC W/YELLOW CONVERTER FINISH.
 - MAXIMUM TORQUE FOR MOUNTING SCREWS: 35/40 in./lbs.
 - AVAILABLE KEY NOS.: J201 THRU J210, J223 & J236.
- EXAMPLE ORDER P/N: 10-21100-201A-03

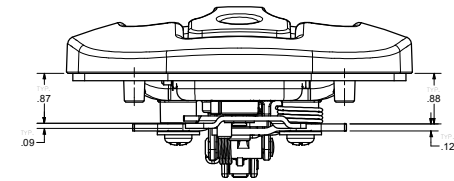

PART NUMBER	FINISH	X DIM.	GASKET TYPE	MOUNTING HARDWARE
11-21100-XXXXA	03, 30, 31, 42, 35	.13	30 DUROMETER EPDM CLOSED CELL SPONGE	21100-MHPK
11-21100-XXXXB	03, 30, 31, 42, 35	.41	50 DUROMETER ETHYLENE VINYL ACETATE SPONGE	21100-MHPK
11-21100-XXXXC	03, 30, 31, 42, 35	.06	TPU - MOLDED	21100-MHPK
11-21100LB-XXXXA	03, 30, 31, 42, 35	.13	30 DUROMETER EPDM CLOSED CELL SPONGE	21100LB-MHPK
11-21100LB-XXXXB	03, 30, 31, 42, 35	.41	50 DUROMETER ETHYLENE VINYL ACETATE SPONGE	21100LB-MHPK
11-21100LB-XXXXC	03, 30, 31, 42, 35	.06	TPU - MOLDED	21100LB-MHPK

KEY LOCKING/BRACKET STYLE
KEY NUMBER
GASKET TYPE
FINISH CODE
CUSTOMER PRINT SHEET 1 OF 3

PATENTED <http://www.eberhard.com/ip>

DIVISION OF THE EASTERN COMPANY CLEVELAND, OHIO 44116-8712

EBERHARD MANUFACTURING CO.

LOCKING HANDLE ASSEMBLY

11-21100-A

C:\Working_Folder\Archive\Proj22110011-1-21100A.CHART (3)11.dwg