

REQUIRED PULL TEST AT OF 2.25 LB - 3.0 LB FOR MOVEMENT 0 - 0.250" CENTER OF CABLE CLAMP WITH STRIKE LATCH IN THE TRIPPED OPEN POSITION

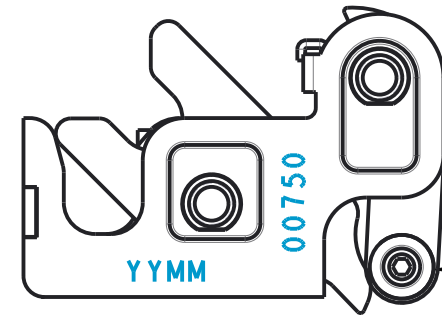

PART	REV	DESCRIPTION	QTY
00749	C	SIDE FRAME, RH, R4.	1
00283	E	SPRING, STRIKE LATCH, RH, 0.079" X 0.180", 0.063" WD	1
00220	H	SPRING, PULL LATCH, RW, 0.650" OD X 0.1225", 0.047" WD	1
00198	H	CABLE CLAMP, POWER GROOVE, CRS, FINISH AFTER ASSEMBLY	1
00197	M	AXLE	2
00196	F	PULL LATCH	1
00194	H	STRIKE LATCH	1
00192	M	MAIN FRAME, RH	1
00091	D	WASHER, CRS, 0.375" OD x 0.155" ID x 0.050"	1
00029	E	SET SCREW, HEX-0.094, #10-32, 0.250	1

APPLY LIGHT OIL TO SPRINGS AND AXELS

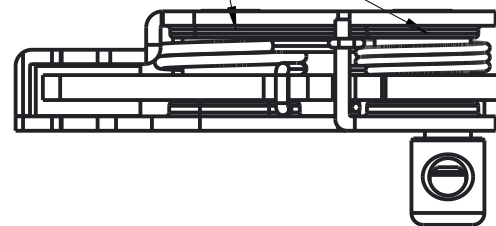

.0100 GAP BETWEEN FRAME AND PULL AND
.0050 GAP BETWEEN FRAME AND STRIKE

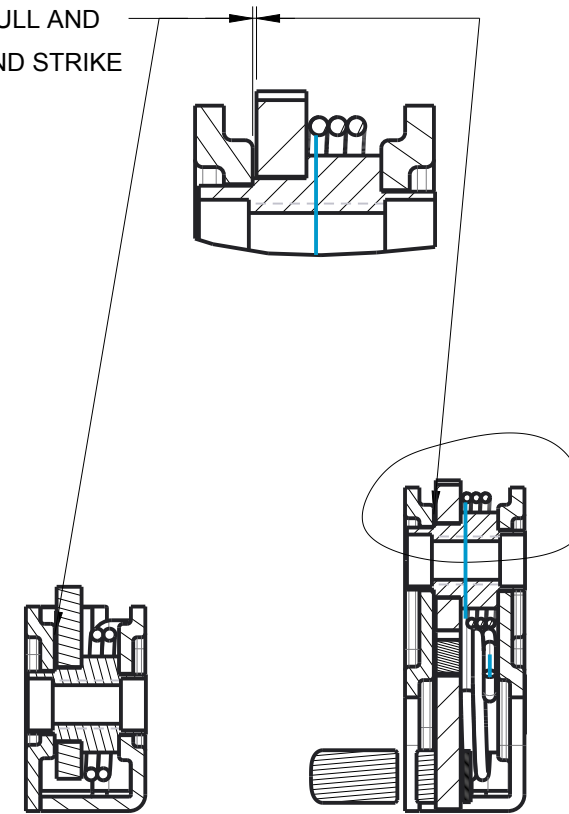

SECTION A-A

SECTION B-B

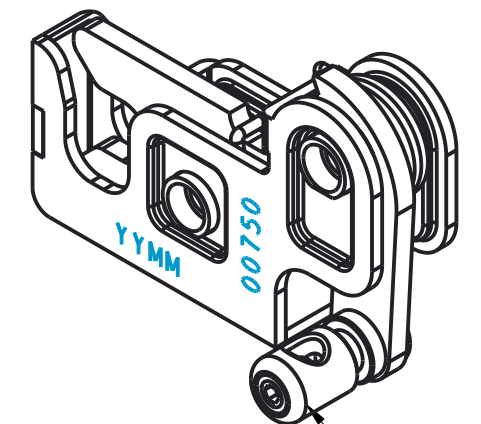
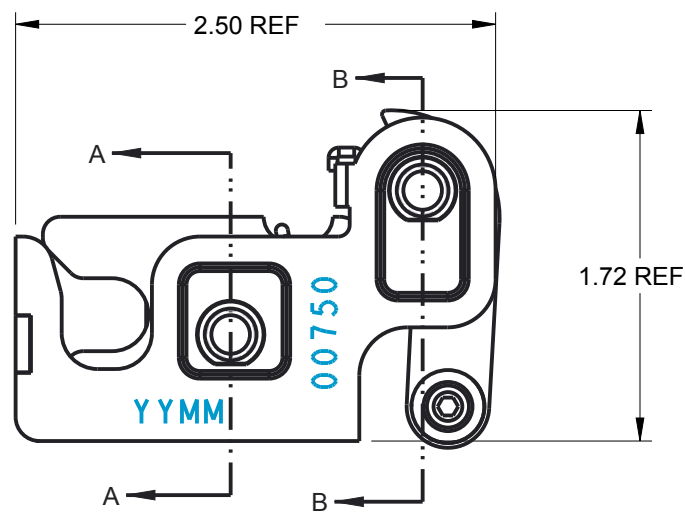
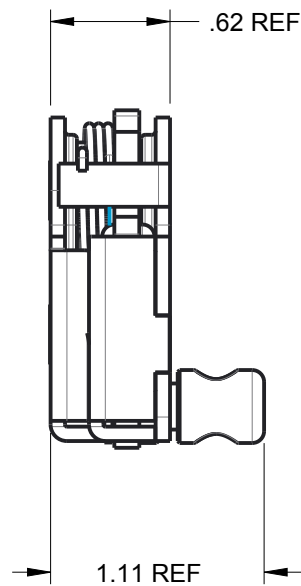

00198 CABLE CLAMP MUST SPIN FREELY IN 00196 PULL LATCH

BUILD TOLERANCES X.X ±0.030 X.XX ±0.015 X.XXX ±0.005 X.XXXX ±0.003 ANGLES ±1° INSP. PT.	FINISH:	BLACK E-COAT COMPLETE ASSY	MATL:	ASSY	DWG SIZE		
	DESCRIPTION:	R4 ROTARY LATCH, RH, 10 lbs					
	REV. LEVEL:	G	REV. DATE:	11-08-17	Detailed by: DTH	Revised by: LJH	DATE: 12-28-09
	ECN #:	368	SHEET 1 OF 1	UNITS:	INCH	SCALE:	

P/N: 00750



www.loadnlocksystems.com